

# TECHNICAL DATA

## VACUUM CASTING SYSTEM MK MINI

**mk**  
technology

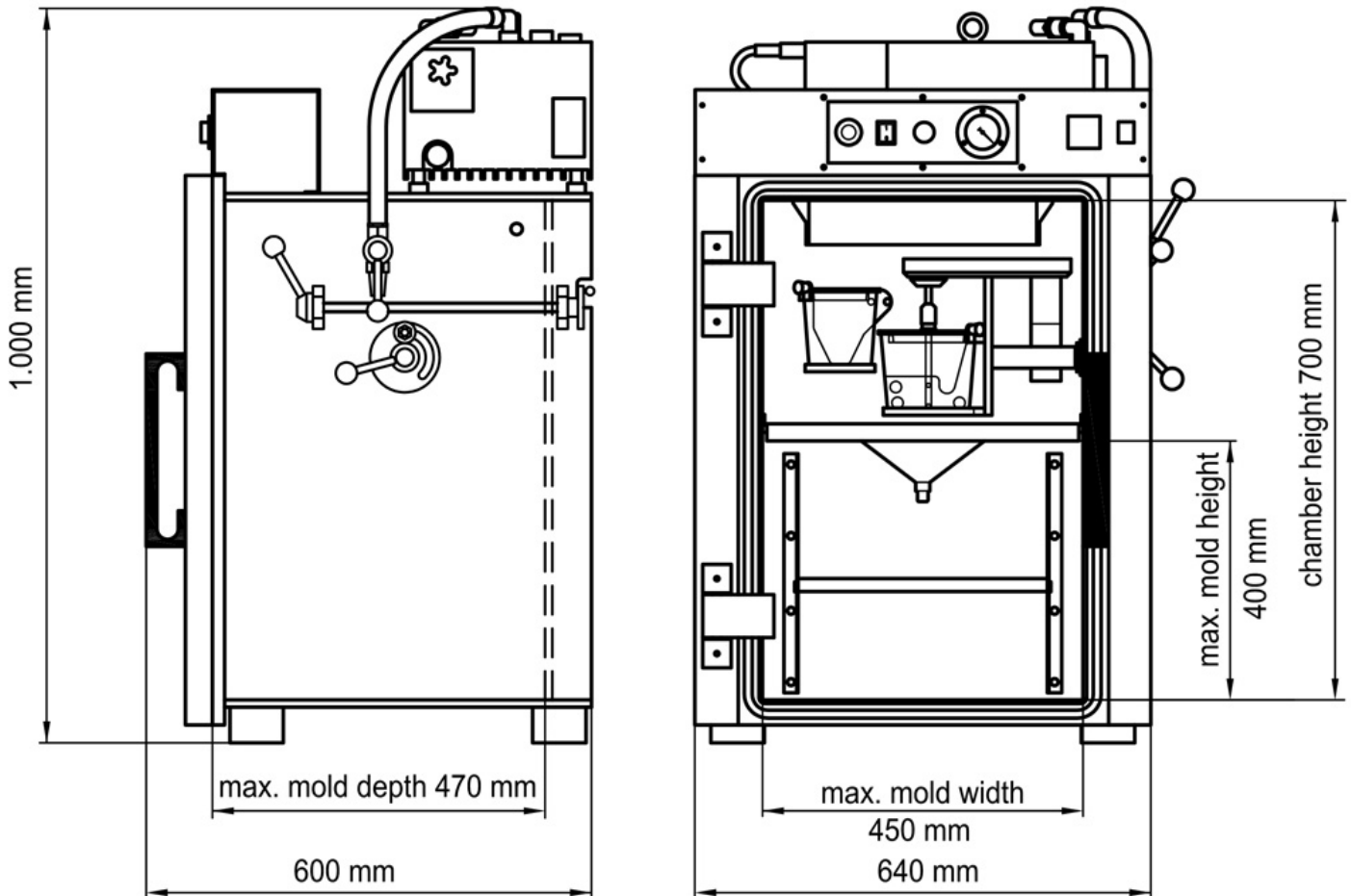

<b>max. casting weight</b>	(g)	1,400
<b>max. mould size</b>	(W x D x H) (mm)	450 x 470 x 400
<b>chamber interior size</b>	(W x D x H) (mm)	450 x 470 x 700
<b>chamber overall size</b>	(W x D x H) (mm)	640 x 600 x 1,000
<b>vacuum power of the pump</b>	(m <sup>3</sup> / h)	25 / ≤0.5 mbar
<b>evacuation time</b>	1,013 → 0 hPa (min)	3
<b>leak time 8</b>	(sec)	25
<b>voltage</b>	(V / Hz)	230 / 50
<b>power consumption</b>	(kW)	0.9
<b>weight</b>	(kg)	250